

Owner's Manual

1640

POWER & PRECISION FOR TODAY'S WOODTURNER



INCLUDED WITH YOUR LATHE

- #2 MT Safe Driver
- #3 MT Live Center
- Knock-out Rod
- 4" Faceplate with Removal Lever
- 14" Toolrest
- Tailstock Wrench
- Levelling Pads
- 4mm, 6mm, 8mm Allen Keys

Table of Contents

INTRODUCTION	4
LATHE SPECIFICATIONS	4
ASSEMBLY & SETUP	5
CONTROL BOX OPERATION (PENDANT ARM)	6
ELECTRONICS	
COMMON PROBLEMS & HOW TO AVOID THEM	7
THE DRIVE	7
PULLEY SELECTION	8
CHANGING THE BELT	8
TOOLREST & BANJO	9
TAILSTOCK	10
GENERAL MAINTENANCE	
LUBRICATION	11
BEARINGS	12
SPINDLE THREAD & SAFETY GROOVE	13
SPINDLE LOCK	13
INDEXING	13
GENERAL SAFETY	14 - 15
LATHE ACCESSORIES	16 - 18
APPENDIX	
1640 FINAL ASSEMBLY	19
HEADSTOCK ASSEMBLY	20
SPINDLE ASSEMBLY	21
BANJO ASSEMBLY	22
TAILSTOCK ASSEMBLY	23
TAILSTOCK SLEEVE ASSEMBLY	24
PENDANT CONTROL WIRING DIAGRAM	25
INDEX GUIDE INSTRUCTION	26
MANUFACTURERS LIMITED WARRANTY	31
ONEWAY CONTACT DETAILS	32

QUALITY INSPECTION SHEET

Horsepower

1½ Hp

2 Hp

Model Number

Serial Number

Date Manufactured

Month:

Year:

Make
Model
Serial Number
Motor: _____

Drive: _____

Electrics:

Voltage: 220 Volts, Phase 1, 50 or 60 Hertz (auto-sensing)

Wiring Method: Three Wire Control

Belt Length & Width:

16" Swing 500 J6

Bearings:

Front 6209 LLBC3 / 2A

Rear 6008 2NKE / C3

Headstock / Tailstock Alignment:

Height - maximum tolerance 0.005 TIR

Actual Difference _____ TIR

Side to Side Tolerance 0.010 TIR

Actual Difference _____ TIR

Introduction

Congratulations on your purchase of a ONEWAY 1640 Lathe.

This manual describes general use and features of a ONEWAY Lathe. It is not meant to be a woodturning instruction book. If you are new to turning, we recommend seeking out a qualified instructor in your area. There are many national and local woodturning organizations that can recommend instructors. If you are unable to take lessons, there are many excellent books and videos available. Proper instruction will ensure that you work safely and that you can use your new lathe at it's optimum.

Lathe Specifications

	1640
Distance between Centers	40"
Overall Length	60"
Swing over Bed	16"
Spindle Taper	#2 Morse Taper
Tailstock Taper	#3 Morse Taper
Weight	575 lbs
Spindle Thread (inboard & outboard)	M33 * 3 ½ RH
Standard Spindle Height	44"
Distance between bedways	1-3/4"

ONEWAY offers different models and configurations of lathe. Refer to your customized Quality Inspection Sheet (inside the front cover of this manual) for the specific details on your machine.

Assembly & Setup

Your lathe comes assembled from the factory and requires minimal assembly. Before setting up the lathe you should select a location.

Location of the Lathe

The best location for the lathe is on a level concrete floor. The electrical box and motor should be kept as cool as possible so do not put the lathe where sun will shine directly on the box or right in front of a furnace vent.

Remove the Lathe

The first step is to remove the lathe from the shipping palette and position it at your desired location.

Install the Belt Covers

The second step is to install the belt covers. There will be a box in the crate with two belt covers. One is for the headstock, the other is for the lathe body.

The Pendant Arm

The pendant arm is shrink wrapped to the lathe body to keep it from swinging inside the crate during transport.

Note: The position of the stop boss depends on where you like the pendant to "lock" in place. This can be set to suit your personal preference.



"BASKET" by Christian Burchard

6. Levelling the Lathe

In the lathe accessories box, there are four metal pads and four large (M12 x 40) set screws and nuts. These pads and screws are for equalizing the pressure on the lathe legs. Insert a set screw at the base of each leg, then put a pad under each setscrew. Screw the set screws down until there is even pressure on each pad and then tighten the locknuts. Doing this will help eliminate vibration caused by uneven floors and the resultant uneven pressure on each leg. It is not necessary to level the lathe.

Q. What about adding Weight?

Our research shows there is no noticeable improvement by filling the tube with sand.

Q. Should I bolt down my lathe?

Each leg is predrilled for bolt down holes. Properly grouting in the legs and bolting the lathe down will greatly increase the stability and safety of the lathe.

Emergency Stop

This button is for "Emergencies". The lathe will coast to a stop if this button is pushed in. Use the regular STOP button for the lathe to brake to a stop. To turn the machine on and off, use the on/off switch on the side of the drive.

Important: This button MUST be in the "OUT" position before turning the lathe on. Twist it to get it in the OUT position.

Forward / Reverse

Set this switch to Forward for normal inboard operation, and Reverse for normal outboard operation. This allows for normal right-handed turning for inboard and outboard. Flipping the switch while the lathe is running will cause the lathe to decelerate to 0 rpm and then re-accelerate in the opposite direction to the selected speed. Changing the direction of rotation while the lathe is running will not harm the motor or the drive, but accessories can unscrew if not locked to the spindle.

Toggle Switch

Up -Long Accel./Decel. (approx 11 seconds)
Down -Short Accel./Decel. (approx 4 seconds)

Speed Pot

Lathe speed is selected with a combination of the pulley selected and the speed pot. Around the speed pot there are 2 rings. The inner ring is marked with the numbers 1 thru 7. Each of these numbers represent the speed x100 (i.e. 2 = 200 rpm). Please note that the lathe does run less than 100 rpm but does not go to zero for safety reasons.

Start Button

Pushing this button starts spindle rotation. Before pushing the button, ensure the speed select is in the appropriate position for the piece you are working on. After pushing the start button the lathe will accelerate in 4 seconds up to the selected speed. If the deceleration selector switch set to LONG, the lathe will take 6 seconds to accelerate up to speed.

TIP: It is always a good idea to set the speed to ZERO, and gradually increase speed to the desired level every time you put on a new piece.

Stop Button

This button stops spindle rotation. Short deceleration is 4 seconds. Long deceleration is 12 seconds. Short or long deceleration is selected with the toggle switch, located on the left side of the Pendant. It is possible when stopping a large piece from high speed that the drive will get overloaded with too much voltage. If this happens, the drive shuts down to protect itself, and the lathe will coast to a stop. If this happens, turn the lathe off (using the ON/OFF switch), wait 20 seconds, and turn the power back on. Move the Deceleration switch to Long and resume working. Most work can be done with the deceleration set to Short.

What are the Rings for?

Inner Ring: Largest pulley in the headstock, smallest pulley on the motor
Outer Ring: Smallest pulley in the headstock, largest pulley on the motor



Common Problems & How to Avoid Them

1. The most common cause of the unit shutting off is stopping large pieces too quickly, therefore causing excess voltage and the drive tripping out (self-protection). If you press the STOP button and the lathe does not brake, but coasts to a stop, this is what has happened. Refer to the section "*What If my Drive trips out?*" on page 8, to reset your Drive.
2. The Drive can also trip out if the speed is changed while turning a piece. To prevent this from happening again, put the deceleration toggle switch into the Long position. Keep in mind that as a piece gets more in balance and you increase the speed, even though you have reduced the weight, the increased speed makes stopping more difficult. This is why the lathe might stop normally when you first start a piece but might trip out later when you increase the speed. You can also reduce braking problems by selecting the proper pulley. It is much easier for the drive to stop the spindle if the belt is on the largest headstock pulley (slowest speed) than if the belt is on the smallest (fastest speed) headstock pulley. Selecting the Long Decel time, will also stop the drive from tripping out when the speed pot is turned rapidly while working on a large piece.
3. The drive unit that comes with your lathe also monitors the amount of current and the length of time that current has been flowing. If the motor has been drawing excess current for too long the drive will shut down to protect the motor. This can happen if the lathe has been running slowly for a long time. To prevent this problem, use the largest headstock pulley (slowest speed) suitable for the job to keep the motor speed high.
4. Sudden high power demands can cause the drive to shut down also. For example, if you have a very large catch, the drive may shut down.

What if my Drive trips out?

The Drive unit that controls the motor is a very sophisticated drive that constantly monitors the motor, incoming power, and itself. If the unit detects a condition that will cause damage to any part of the drive system, it will shut itself down and the motor will coast to a stop. If this happens, the lathe will not respond to any input from the pendant control. To reset the Drive, turn the power off, **let the lathe sit for 20 seconds**, and then turn the power back on.

The Drive (Inverter)

The drive unit can be programmed to function in many different ways. There are over 60 programmable parameters in the AC controller.

Radio Interference

The drive unit in the lathe broadcasts radio interference that affects AM radio. To fix this problem the drive can be fitted with a **RFI Filter** to eliminate radio interference. Refer to the "Lathe Accessories" section of our Website (www.oneway.ca) for more information on the RFI Filter.

Pulley Selection

ONEWAY Lathes use an AC, variable speed, control and a two-step pulley to give a high top speed and good low speed torque. The drive and motor work best when the motor is running fast.

Which belt setting is best?

The best pulley to use is the one that gives the range you want for the piece you are working on.

If, for example, you want to turn a 12" bowl you would select the slowest pulley. This pulley will give lots of torque for the rough turning and go fast enough for finish turning.

The following guidelines are only approximate and must be reduced if the piece you are working on is out of balance, checked, or in any other way flawed. These speeds are only for side grain pieces:

Changing the Belt

1. Stop the lathe.
2. Remove the headstock and motor belt covers.
3. Loosen the speed handle. Use the motor lifter to lift the motor, then lock it (in the raised position), using the speed handle.
4. Move the belt to the desired step on the headstock pulley, and then to the corresponding step on the motor pulley. Ensure the belt is correctly located in the grooves on both pulleys.
5. Grasp the lifting lever and loosen off the speed handle. Lower the motor, and apply downward pressure (25-50 lbs). While still applying downward pressure, tighten the speed handle to lock the motor in place. Check the belt again to ensure it is seated correctly (in the grooves), on both pulleys.
6. Replace both belt covers.

- Bowls less than 11" - small headstock pulley (fastest speed)
- Bowls larger than 11" - large headstock pulley (slowest speed)

What speed should I run the lathe at?

A general rule of thumb to determine the lathe speed:

Multiply the rpm x bowl diameter and the answer should be between 6000 and 9000.

For example:

$$6" \text{ bowl} \times 1000 \text{ rpm} = 6000$$

$$6" \text{ bowl} \times 1500 \text{ rpm} = 9000$$

Therefore, if you are turning a 6" bowl, the lathe should run somewhere between 1000 and 1500 rpm.

Note

This is only a guideline, and speed must be reduced to compensate for out-of-balance or flawed pieces.

Toolrest & Banjo

The banjo (toolrest base) has a patented clamping mechanism that ensures tight and consistent clamping position, regardless of where the banjo is clamped. To ensure continuing smooth operation, lubricate the mechanism whenever it seems to be getting sticky.

Toolrest Clamp Lever

The toolrest clamp lever can be adjusted to clamp in any position. To change the position of this lever, unscrew the four screws that hold the clamp nut in place, rotate it to the desired position and re-fasten the nut with the screws.

Note: There are 8 holes in the clamp nut, allowing adjustments of 1/8 rotational increments. The handle clamp position is an individual preference, but the 5 O'clock position is a good place to start.



Banjo Clamp Handle

The banjo handle will clamp either to the left or right. Generally the handle is adjusted so that when it is clamped, the handle is clear of the bed. This allows the handle to be clamped in all positions except over the bed. The clamp handle position can be adjusted via the Nylock Nut, underneath the banjo.



PAINTED BOWL by David Loewy

Tailstock

The tailstock has a #3 Morse Taper and a 5/16" thru hole for lamp hole augers. The thread on the quill is a 6 pitch Acme thread that allows rapid feed in and retractions for drilling with the tailstock.

The Quill Lock:

The quill lock is located on the side of the tailstock. It should be snugged up when using a live center. The lock does not have to be tightened excessively. This lock does not stop the quill from backing off, that is done by the feed screw mechanism. The lock removes any play between the quill and the bore, to help reduce vibration when you are working between centers.

The Clamp Handle

This handle clamps the tailstock to the bed. The position of the handle (when clamped) is adjusted by means of a shim stack on the bottom of the clamp block. To change the lock position, loosen off the two bolts in the clamp block, add or remove shims, and re-tighten the bolts.

The #3 Morse Taper

The Morse taper in the tailstock is greatly affected by how clean the taper is. Even a small amount of dust, or oil, will significantly reduce the drive force that can be exerted by the tailstock before accessories will spin in the taper.

Always wipe any accessory and the taper with a clean rag before putting the accessory into the tailstock.

Installation of Accessories: To install an accessory in to the tailstock, wind the barrel out 1". Put the accessory in the barrel, and snap it into the taper.

Removal of Accessories: All Oneway Tailstocks are equipped with a self-ejecting mechanism. To remove an accessory, wind the barrel back until the accessory pops out.

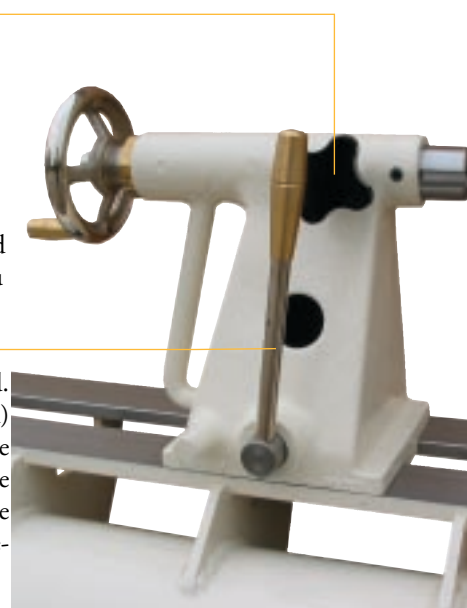

ONEWAY Lathes, like any mechanical device, needs lubrication to function at its optimum.

Woodturning creates dust and turning wet wood sprays water and chemicals onto the lathe. Some of these chemicals are acidic and can quickly rust the bed.

Minimizing Rust

To minimize bed and tailstock quill rust, apply a heavy-duty paste wax. Doing this will not noticeably affect clamping.

How should I care for the Lathe?

After turning, the lathe should be wiped down - particularly the bed. Wiping an oily rag over exposed metal will help keep your lathe functioning better and last longer. Oil on the bed should be wiped off before using the lathe so the tailstock and banjo clamp tightly.

What are the most important areas?

There are two areas on the lathe that require lubrication: the **tailstock** and the **banjo** clamping.

1. The Tailstock

The tailstock quill is a precision fit and to maintain factory performance it should be kept lightly oiled at all times. Wind the quill all the way out, put a few drops of oil on the barrel and wind it in. Putting oil on the clamping mechanism will help ensure long life and good clamping force. To oil the

clamp mechanism put a few drops on the shaft through the hole in the back of the tailstock.

2. The Banjo

The banjo uses a patented mechanism that eliminates flex in the shaft and ensures tight clamping over the entire range of the banjo. Lubricating the mechanism will ensure that the clamping force is used to clamp the banjo, not to overcome friction in the mechanism. Any anti-seize lubricant will work but we find that Fel-Pro anti seize lubricant C5-A works well.

To lubricate the Banjo, remove the banjo from the lathe and lubricate the sliding cam.

Notes

- You should only have to lubricate the mechanism when it is not clamping well.
- Putting oil on the shaft helps ensure the banjo continues to slide freely.

There are four spindle bearings in the headstock. These bearings are sealed and lubricated from the factory and should never need adjustment or lubrication. The bearings and the spindle in your lathe are very large and designed to take normal woodturning forces for a long time. The best way to ensure long bearing life is to **never hammer the spindle**.

Are the Bearings supposed to get this hot?

Due to the size and the preload on the bearings, the lathe will run quite hot when it is new. As the bearings break in they will run cooler but will still get warm. Each lathe is run in at the factory and checked for excess temperatures, but it's a good idea to keep the speed below 2000 rpm for the first 30 hours of operation. This allows excess grease in the bearings to escape and for the seals to break in.

Replacing Bearings

When replacing the bearings it is best to replace the front bearings with a matched set from ONEWAY. The rear bearings can be replaced with any equivalent bearing.

How do I Replace the Bearings?

To replace the bearings you must remove the spindle.

1. The first step is to take the belt off the motor pulley and pull the belt part way thru the headstock belt change hole.
2. Remove the six bolts in the spindle nose cap. Grab the nose cap and the entire spindle assembly should slide out.

What if the Spindle won't slide out?

If it's tight, take two of the bolts you just removed and put them into the two tapped holes in the nose cap. Tighten them alternately and this will jack out the spindle.

Note: Be careful when removing the spindle as the assembly weighs over 25 lbs.

3. Once the Spindle has been removed from the Headstock, the old bearings can be

removed from the spindle assembly and the replacement bearings can be installed.

Important

If you do not have a proper set of bearing tools it is a good idea to send the spindle back to ONEWAY to prevent damage to the spindle and to the new bearings.

Re-installing the Spindle

Now that you have the new bearings installed on the Spindle assembly, the Spindle needs to be re-installed into the Headstock. You will use the Tailstock & Live Center to help "align" the Spindle in the Headstock.

4. Insert the Spindle into the Headstock so that the rear bearings are somewhat lined up with the rear bearing housing.
5. Bring the tailstock up close to the Spindle and clamp in place.
6. Insert the Live Center (with **Full Point Cone** attached) into the Tailstock.
7. Use the Live Center to help align the Spindle by moving the Live Center in so that the Full Point Cone is inside the Spindle bore.
8. Once the Spindle is aligned, remove the Live Center and with a piece of wood between the Tailstock barrel and the Spindle, press the Spindle most of the way in using the Tailstock. Stop just before the Locating Ring is engaged.

Note - At this stage the Nose Cone (on the Spindle) should still spin freely.

Important - Make sure you use **all six bolts** to "press" the Spindle back into place. This should be done in an alternating pattern. For example, if you were to number the bolts (in a clockwise sequence) 1 2 3 4 5 6, then you would tighten them in an order similar to 1 3 5 2 4 6.

9. After all six bolts are fully seated and snugged down, the "Nose Cap" (that the six bolts are screwed into) should be sitting flush with the headstock.

Spindle Thread & Safety Groove

The spindle of ONEWAY Lathes are threaded M33 x 3.5 RH and has a locking (safety) groove to help ensure that accessories on the spindle do not loosen off during use. There are two set screws on all ONEWAY accessories that fit your lathe. Screw the accessory secure-

ly onto the lathe and then tighten the two set screws using an M4 allen key. **Note:** Metric threads have two terms. The first term (M33) refers to the diameter of the spindle in millimeters and the second term (3.5) refers to the distance between threads in millimeters.

Indexing

The spindle indexing pin located at the top, on the back end of the Headstock.

It is locked into an engaged or disengaged position with a set screw.

Where is the Indexing Pin Set screw located?

The set screw for the Indexing Pin is located at the top and rear of the headstock and requires a 4mm Allen Key (supplied) for operation.

How is it used?

To use the spindle indexing, loosen the set screw, slide the pin forward while rotating the spindle by hand. The pin will engage one of 48 holes. Lock the pin in place with the setscrew.

Where's the Indexing Ring?

To see the indexing ring, open the belt change lid and look at the face of the largest pulley. The numbers 1 thru 48 are engraved on the face of the pulley

There is no mechanism to mark what hole you are using supplied with the lathe. Clipping a clothespin on the headstock in the belt change hole works great and allows you to select what index numbers you work with. You can also put a strip of masking tape across the belt hole and use that.

Refer to page 26 for a guide for indexing positions titled "Index Guide Instruction".

Spindle Locking Mechanism

When removing accessories it is necessary to lock the spindle.

Where will I find the Spindle Lock?

The spindle lock is located at the back end of the headstock.

How do I Lock the Spindle?

Lift the lever from the disengaged position and push it in gently. At the same time slowly rotate the spindle by hand. The spindle lock pin will engage a hole

in a plate in the headstock. When the pin locks in place drop the lever into the second slot to keep the spindle locked in place.

How do I Unlock the Spindle?

To unlock the spindle lift the lever, pull it back and drop it into the unlocked position.

Will I damage the Lathe if it's started with the Spindle Lock engaged?

If you start the lathe with the spindle lock in place the lathe will not be damaged. If you do start the lathe with the spindle locked, press the stop button and remove the spindle lock.

What if the Lathe shuts off?

Leaving the lock pin in with the lathe started will eventually cause the lathe to shut off.

To restart the lathe in this situation it will be necessary to turn the lathe off and let the lathe rest for 20 seconds (to reset itself). Apply power to the lathe again, to continue turning.



General Safety

Woodturning is an activity that can involve heavy workpieces revolving at high speeds.

ONEWAY Lathes are very heavy solid machines and can rotate pieces faster than most other lathes.

Be Aware!

ONEWAY Lathes are also very quiet. It's easy to run the lathe faster than you think it is going.

Bark, shavings and pieces of wood can fly from the lathe with considerable force, unexpectedly, at any time.

Wear Protection

Always wear face protection to prevent injury in such instances. Safety glasses will not protect your whole face. Wear a full-face shield and if possible, wear lung protection as well. A powered respirator is a good investment for any woodturner.

Avoid the Firing Line

The best way to avoid injury is to stay out of the firing line. Professional instructors can teach you where to stand to minimize injury potential from flying debris. As when working with any tool, a sensible approach, with simple safety precautions, should be followed.

Hand Wheel Safety

Do not use a ONEWAY 6" or 8" Faceplate as a hand wheel. The reinforcing ribs on this faceplate causes a dangerous pinch area with the spindle index and locking mechanism if used as a hand wheel. If you feel a hand wheel is required you should make one from wood. Make sure that at least 1½" clearance exists between an installed hand wheel and the spindle lock mechanism. Optionally order **part# 2802**. This is a hand wheel hub designed for this purpose.

Common Sense Safety Rules

1. Always keep guards in place.
2. Always wear eye protection. Use safety glasses or a full face shield when appropriate. Work in a well-lit environment.
3. Wear lung protection. Wear a dust mask if cutting dry/dusty wood and when sanding.
4. Do not wear loose clothing. Shirts should have short sleeves. Never wear a tie when working with any power equipment.
5. Never wear jewelry (i.e. watches, necklaces, rings and bracelets) while working with a wood lathe.
6. Long hair should be tied up or stuffed into a hat. Long beards can get caught and should be tied back.
7. Keep your shop floor free from objects that can be stumbled over. Woodturning generates lots of chips, which will quickly hide any hazards on the floor. Keep the work area clean. Accidents are less likely to occur in a tidy work area where all sharp tools are put in their proper place.

Before You Start

8. Check your lathe and work area before you start to make sure that everything is in proper working order and there is nothing lying loosely on the lathe. Ensure that the proper belt is selected and that the **speed pot is dialed down to the lowest speed**. Make sure that the workpiece is fastened securely to the lathe and that the **toolrest and banjo are tightened**. Rotate your work manually before starting power. This will

both assure clearances of toolrest, bed, etc. as well as assuring that chuck keys or wrenches have been removed.

While You Are Working

- 9. Stop the lathe before moving the toolrest. If you move the rest while the lathe is running you risk damaging the lathe, your workpiece and your fingers. Never touch the spinning wood.
- 10. Do not force your tool. A sharp tool used properly will remove wood very quickly without being forced. Pushing hard will lead to many problems, not just safety problems. Always use the proper tool for the job. Keep your tools sharp and clean for best results. Sharp tools are more predictable and behave better than dull tools.
- 11. Never wrap rags or abrasives around your fingers. They can get caught and cause severe injury.
- 12. If you have small children around, please be aware that they can walk into the firing line and be hit with chips or other debris.



“IPU POD” by Mike Lee

- 13. If you hear your lathe making a new sound, stop and investigate. New sounds are usually a sign of something going wrong.
- 14. Do not turn obviously damaged or weakened wood. Check for splits, cracks or weak spots before mounting it on the lathe. If turning a piece of glued wood, ensure that glue joints are secure.
- 15. Never leave the lathe running while unattended. Wait until the lathe comes to a complete stop before leaving the area.
- 16. Always make sure that the lathe is running in forward while turning inboard, and in reverse while turning outboard.
- 17. Disconnect the power source when the motor is being mounted, connected or reconnected.
- 18. **The Tool Rest:** adjust the tool rest height properly; adjust the tool rest so that it is as close to your work piece as possible; remove the tool rest when sanding or buffing.

Curved Toolrests

To make a nice curve on a bowl, the curve needs to be cut in one shot. On medium to large sized bowls, you need a curved toolrest to do this. The ONEWAY curved toolrest is gently curved to help bowl turning from green turning to the final finish cut.

Increased Safety & Control

The curve allows you to position the rest closer to the piece you are turning. Therefore, your tool will not have to hang so far off the rest. This not only increases the safety factor, but means you have greater control of your tool. Made from stainless steel it will not rust and will last a lifetime.

There are two different shapes available with a 1” post, General Purpose and Exterior



1” General-Purpose Curved Toolrest
Order No. 3037



1” Exterior Curved Toolrest
Order No. 3038

Spindle Adaptor

ONEWAY offers special adaptors to fit your existing tooling (if required) for most standard machines.

Spindle Adapter Chart		
From	To	Part #
M33 * 3.5 RH	3/4 - 16 RH	2596
M33 * 3.5 RH	1 - 8 RH	2567
M33 * 3.5 RH	1 - 12 RH	2598
M33 * 3.5 RH	1-1/8 - 7	2594
M33 * 3.5 RH	1-1/8 - 8 RH	2595
M33 * 3.5 RH	1-1/8 - 8 LH	2956
M33 * 3.5 RH	1-1/4 - 8 RH	2566
M33 * 3.5 RH	1-1/2 - 6 RH	2565
M33 * 3.5 RH	1-1/2 - 8 RH	2564
M33 * 3.5 RH	M30 * 3.5 RH	2575
1 - 8 RH	M33 * 3.5 RH	2961
3/4 - 16 RH	M33 * 3.5 RH	2962
<i>anything else</i> <i>(two piece adaptor)</i>	M33 * 3.5 RH	3232

Hand Wheel Hub

Wood is screwed to this hub so a custom hand wheel can be made. Available to ONEWAY Lathe owners as they are supplied at cost

Spindle Extension

This extension is threaded M33 * 3.5 , female on one end, male on the other, which screws onto the spindle and effectively lengthens it by 2-7/8 inches.

Remote Start/Stop (Order No. 2787)

A remote START/STOP control is an available accessory. This option is especially convenient when turning outboard or on a large bed extension. It is wired into the control box and can be attached anywhere on the lathe with its magnetized control box.

Faceplates

A wide range of faceplates are available for your lathe. These are available in five different sizes:

- 3" Faceplate Carbon 2391-0355cr
- 4" Faceplate Stainless 2391-0355ss
- 6" Faceplate 2393-0655
- 8" Faceplate 2394-0855
- 10" Faceplate 2395-1055

The 10" faceplate requires an adaptor.



Live Center Adaptors

Now available are Live Center Adaptors. These adaptors are threaded to screw onto ONEWAY Live Centers, effectively changing the $\frac{3}{4}$ " - 10 TPI thread of the Live Center to the size of the lathe spindle. With one of these adaptors, a very precise centering method can be used:

1. Attach a bowl blank to a faceplate.
2. Turn the outside of the bowl, including a foot or tenon to chuck it on.
3. Using the Live Center adaptor, attach a chuck or faceplate to the Live Center.
4. Move the tailstock (with the Live Center / chuck assembly attached) up to the bowl, and grab the foot or tenon on the bowl while it is still attached to the faceplate and lathe.
5. Remove the faceplate, bowl blank and chuck from the lathe.
6. Remove the faceplate from the bowl blank.

You can now screw the chuck onto the headstock, and your bowl will be very precisely centered and ready to be hollowed out.

Live Centre adaptors are available in the following thread sizes:

$\frac{3}{4}$ " - 10 TPI to M33 * 3.5

Order No. 3065

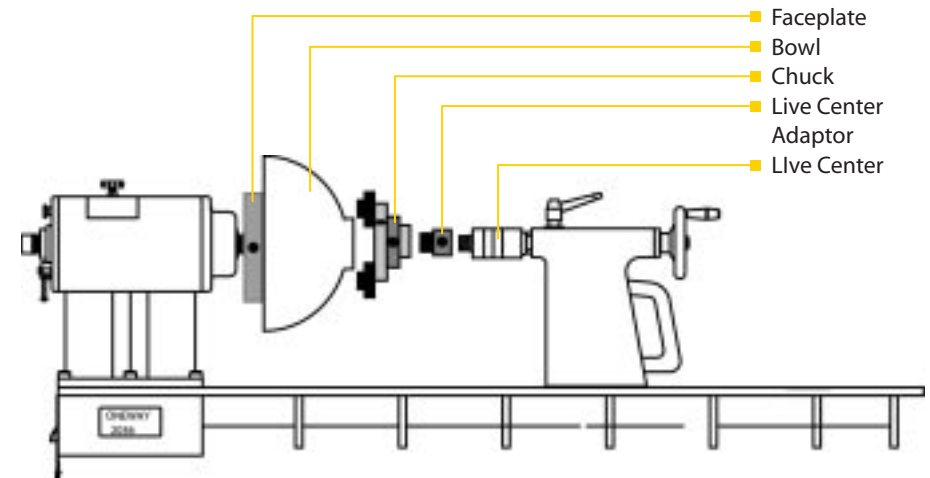

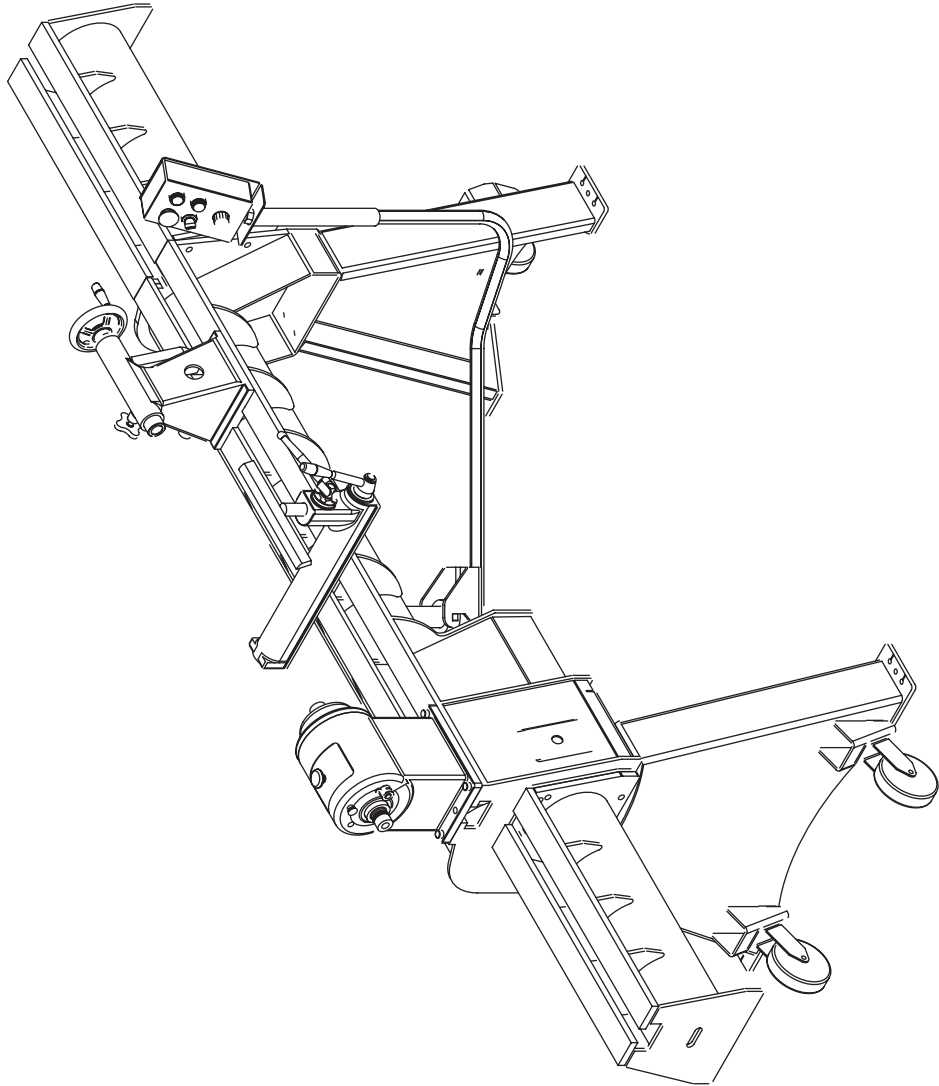

Headstock Assembly with Re-Order Numbers

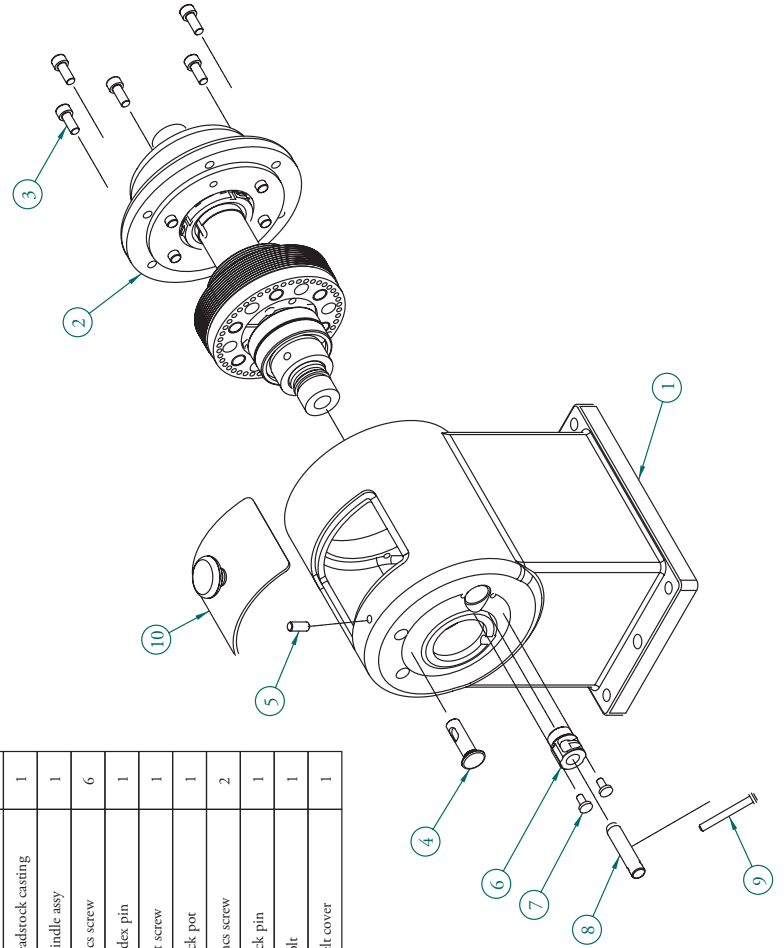

Item	Part #	Title	Qty
1	F0021	headstock casting	1
2	F0025	spindle assy	1
3	M8 x 20	shcs screw	6
4	2453	index pin	1
5	M8 x 20	ser screw	1
6	2450	lock pot	1
7	M6 x 12	bhcs screw	2
8	2451	lock pin	1
9	2452	bolt	1
10	F0085	belt cover	1

Spindle Assembly with Re-Order Numbers

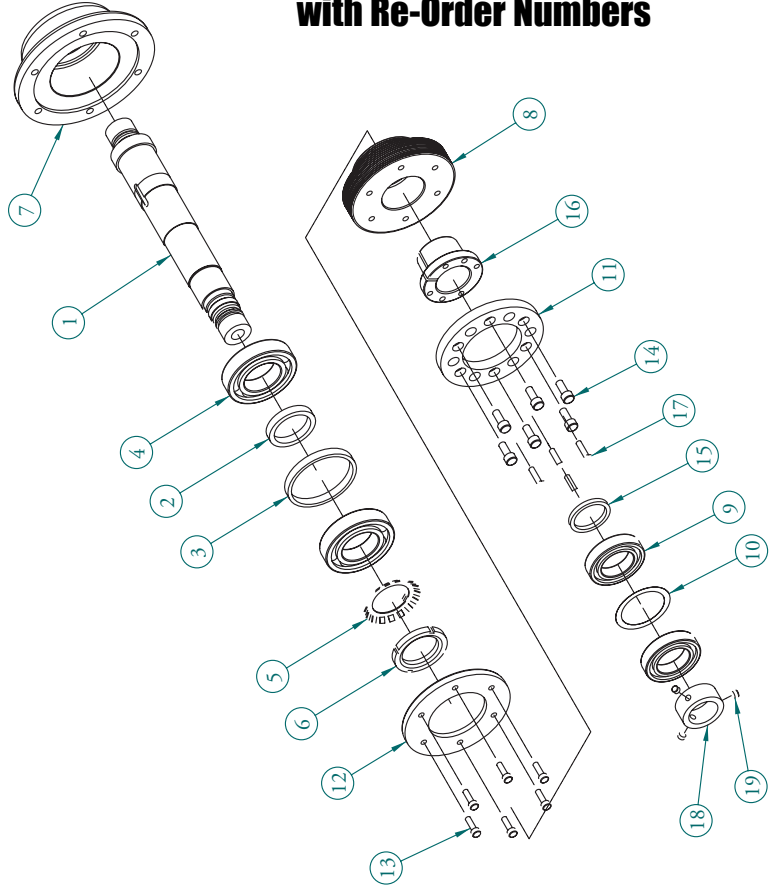

Item	Part #	Title	Qty
1	H0023	spindle shaft	1
2	2372	Brg Spacer	1
3	2370	Brg Spacer	1
4	6209 LLBC32A	bearing	2
5	1W-09	notched washer	1
6	KM-09	lock nut	1
7	2316	Nose Cap	1
8	H0024	Pulley	1
9	6008-2nlc	bearing	2
10	2765	Shim Spl Rear Brg	1
11	2340	Index Ring	1
12	2321	Brg Clamp Ring	1
13	M6 x 20	slcs screw	6
14	M8 x 20	slcs screw	6
15	2735	Rear spl spacer	1
16	2341	Split Bushing	1
17*	M6 x 25	hex bolt	4
18	2728	Spacer spl outboard	1
19	2605	Set screw	3

Banjo Assembly with Re-Order Numbers

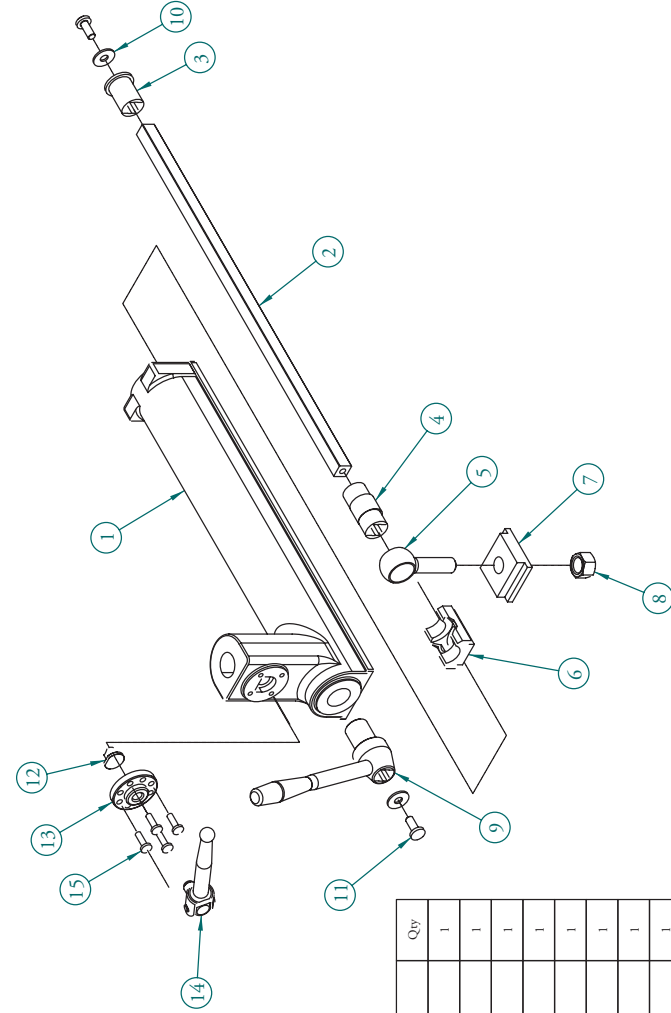

Item	Part #	Title	Qty
1	H0036	banjo	1
2	H0081	Lock Shaft	1
3	2860	bushing	1
4	2432	cam	1
5	2444	eyebolt	1
6	2443	cam support	1
7	2410	T nut	1
8	M16	Nylock nut	1
9	2495	handle assy	1
10	M8	washer	2
11	M8 x 20	burton head screw	2
12	2454	pressure pad	1
13	2457	locking pad	1
14	2675	handle assy	1
15	M6 x 20	burton head screw	4

Tailstock Assembly with Re-Order Numbers

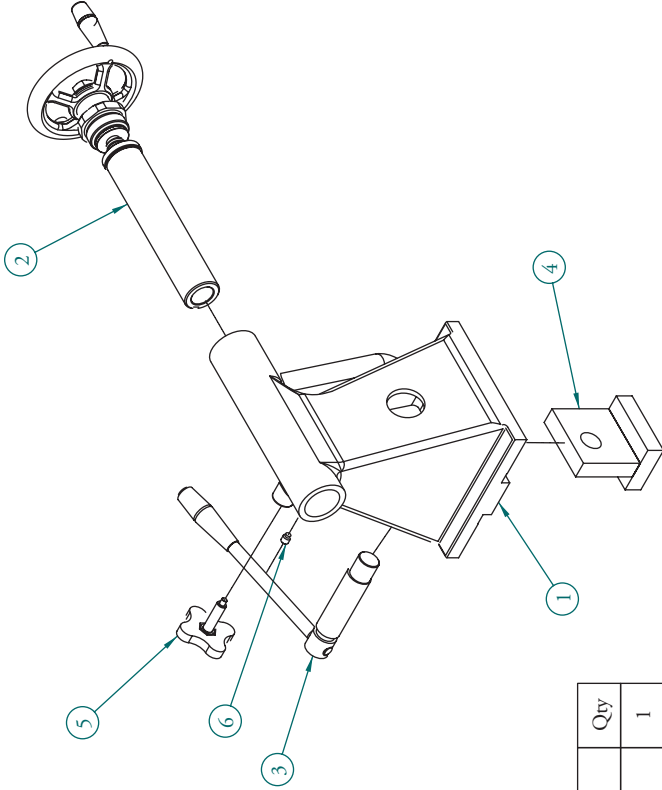

Item	Part #	Title	Qty
1	H0033	tailstock body	1
2	2363	barrel assy	1
3	H0063	handle assy	1
4	2425A	clamp block assy	1
5	H0069	lock screw assy	1
6	M8 x 10	dog point screw	1

Tailstock Sleeve Assembly with Re-Order Numbers

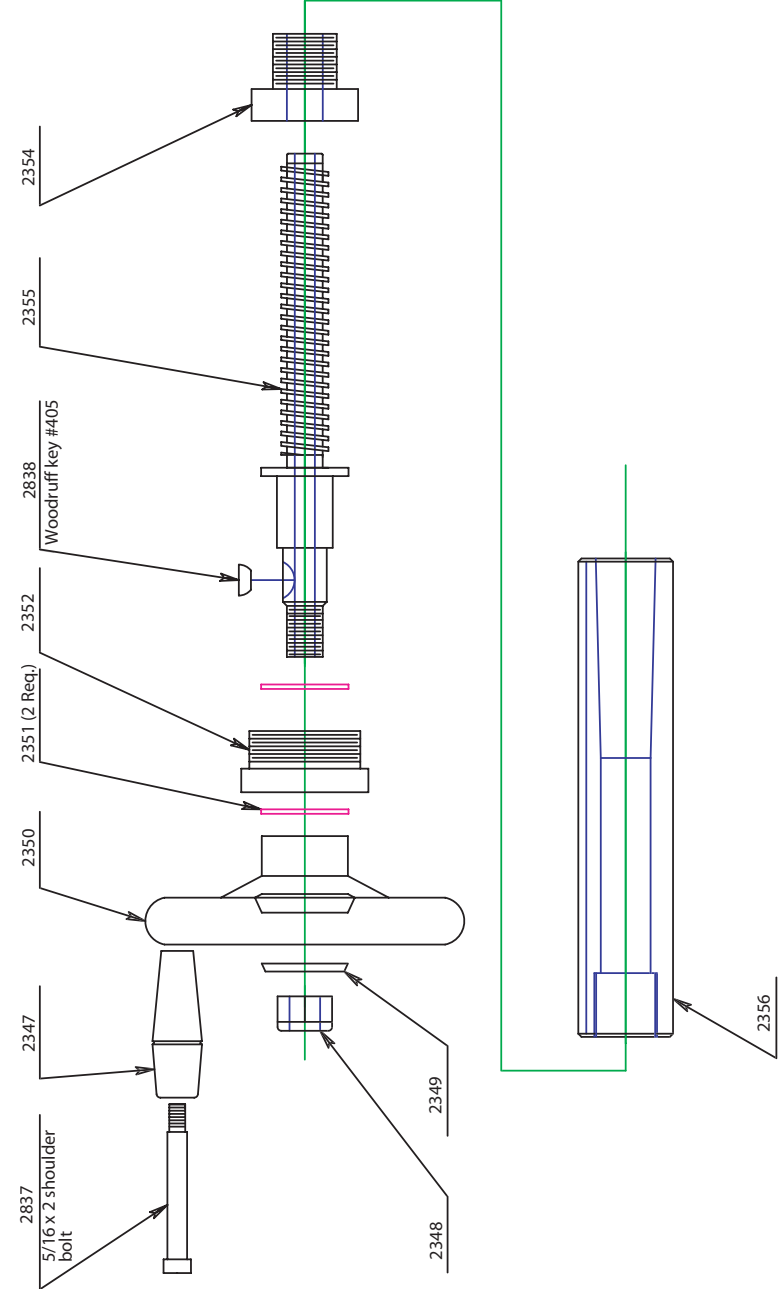

Pendant Control Wiring Diagram

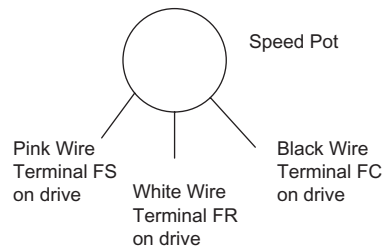
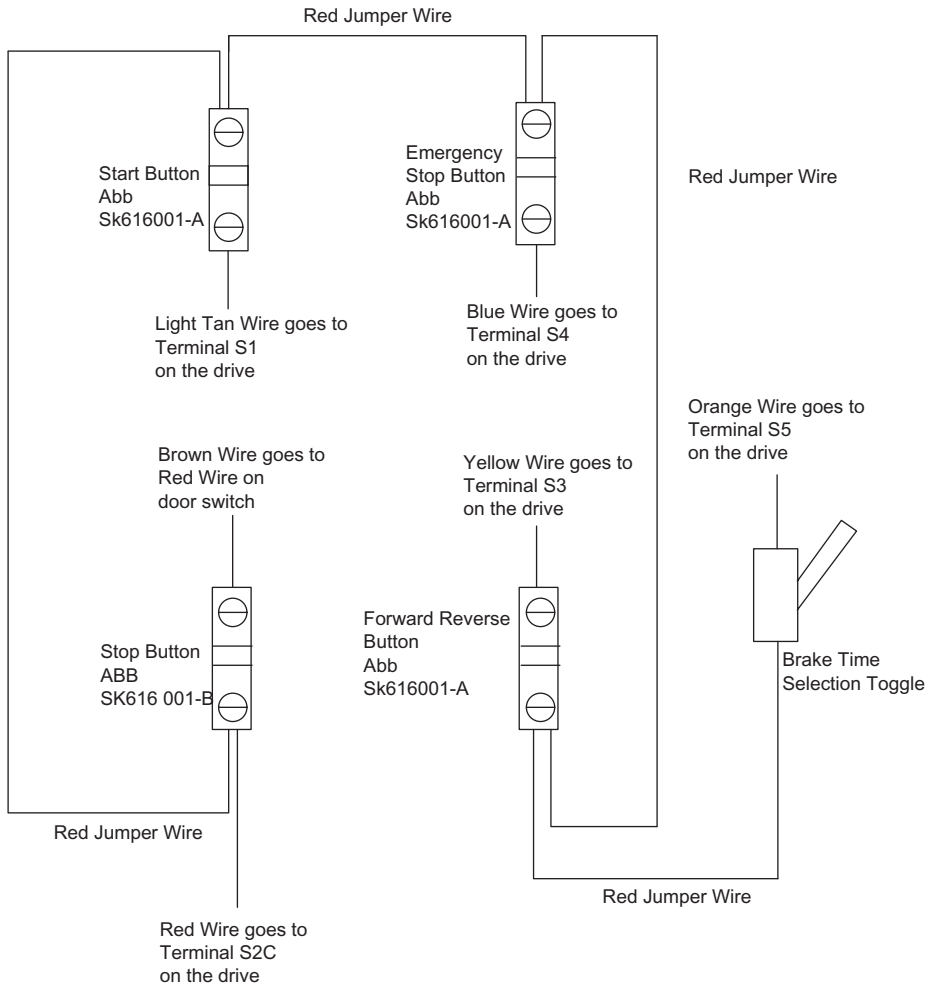

Indexing Guide

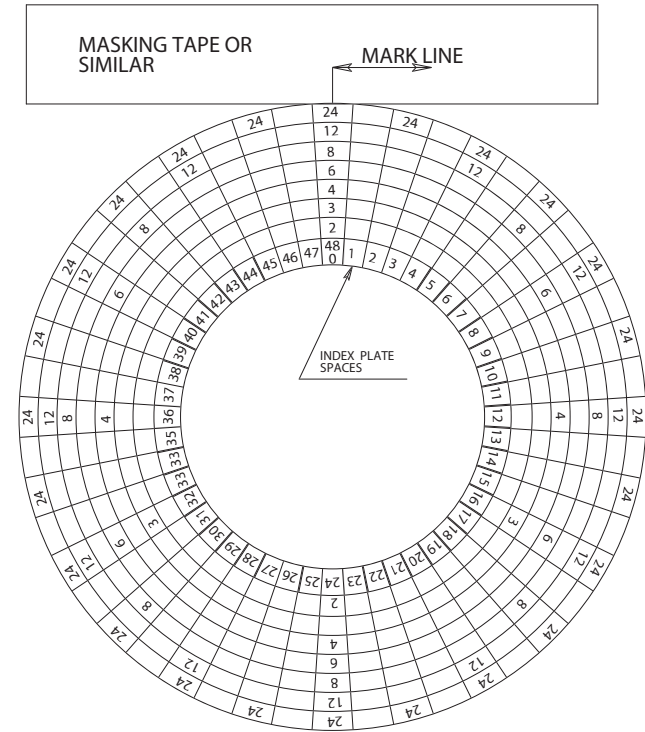

Your index plate has 48 spaces of 7.5 degree which can give you 2-3-4-6-8-12-24 and 48 divisions. We have made this chart as a guide only for easy reference as to what number to use.

Manufacturers Limited Warranty

Date Purchased: _____

This Oneway product is backed by a warranty period of 5 years from the date of purchase. Non-manufactured parts (i.e. Drive, Motor, Bearings etc) are not covered under this warranty; please refer to the relevant Warranty information provided with the lathe.

Oneway hereby agrees to repair or replace, any defects due to faulty material or workmanship, provided that:

1. Oneway has reasonable opportunity to verify the alleged defect by inspection.

Oneway reserves the right to charge customers for replacement parts until the defect is verified whereupon a full refund will be issued.

2. The warranty period has not elapsed. Proof of purchase date (sales receipt etc.) is required prior to any repair taking place.
3. The product has not been altered or modified in any way.
4. The product has not been subjected to misuse, abuse, negligence, or was not used in a "normal" manner.
5. All transportation costs incurred in returning the product to Oneway Manufacturing is pre-paid by the customer.
6. Defective parts will be returned using the **Canadian** or **U.S Postal Service** (ground) or relevant Postal Service (surface) if overseas, packaged appropriately, and labeled "Defective Goods - Returning to Manufacturer".

***Important:** Please call us prior to returning the defective parts.*

This warranty does not cover any costs or damages arising directly or indirectly from the operation of this product.

No other guarantee, written or verbal, is authorized by Oneway Manufacturing.

Our policy is one of continuous improvement. We therefore reserve the right to change the specification and/or design without notice.



241 Monteith Ave
Stratford, Ontario, N5A 2P6, Canada
Phone: 1-519-271-7611
Fax: 1-519-271-8892

1-800-565-7288

www.oneway.ca



*"Nested Set"
by David Lancaster*